



Heavy Equipment Maintenance and Repair

General Assessment Information

Blueprint Contents

General Assessment Information	Sample Written Items
Written Assessment Information	Performance Assessment Information
Specific Competencies Covered in the Test	Sample Performance Job

Test Type: The Heavy Equipment Maintenance and Repair industry-based credential is included in NOCTI's Job Ready assessment battery. Job Ready assessments measure technical skills at the occupational level and include items which gauge factual and theoretical knowledge. Job Ready assessments typically offer both a written and performance component and can be used at the secondary and post-secondary levels. Job Ready assessments can be delivered in an online or paper/pencil format.

Revision Team: The assessment content is based on input from secondary, post-secondary, and business/industry representatives from the states of Kentucky, Michigan, and Pennsylvania.



47.0302- Heavy Equipment Maintenance Technology/Technician



Career Cluster 16- Transportation, Distribution, and Logistics



49-3031.00- Bus and Truck Mechanics and Diesel Engine Specialists

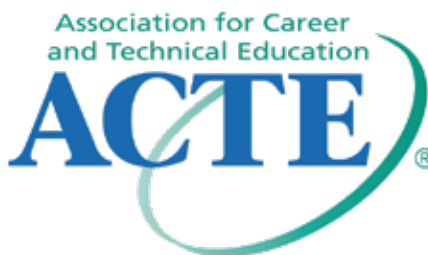

The Association for Career and Technical Education (ACTE), the leading professional organization for career and technical educators, commends all students who participate in career and technical education programs and choose to validate their educational attainment through rigorous technical assessments. In taking this assessment you demonstrate to your school, your parents and guardians, your future employers and yourself that you understand the concepts and knowledge needed to succeed in the workplace. Good Luck!

(Continued on the following page)

General Assessment Information (continued)



The Automotive Lift Institute (ALI) applauds students who successfully complete a Career and Technical Education program and validate their knowledge and skills with credentials such as ALI's lift safety certificate course and NOCTI industry-based assessments. As the world's most-widely recognized source for promoting the safe design, construction, installation, inspection, and use of automotive lift products, ALI believes in the importance of third-party, industry-driven credentials and their importance as a foundation for defining a technician's skill level throughout their career.



NATIONAL COLLEGE CREDIT RECOMMENDATION SERVICE
University of the State of New York - Regents Research Fund

In the lower division
baccalaureate/associate degree
category, 3 semester hours in
Heavy Equipment Maintenance
and Repair

Written Assessment

NOCTI written assessments consist of questions to measure an individual's factual theoretical knowledge.

Administration Time: 3 hours

Number of Questions: 174

Number of Sessions: This assessment may be administered in one, two, or three sessions.

Areas Covered

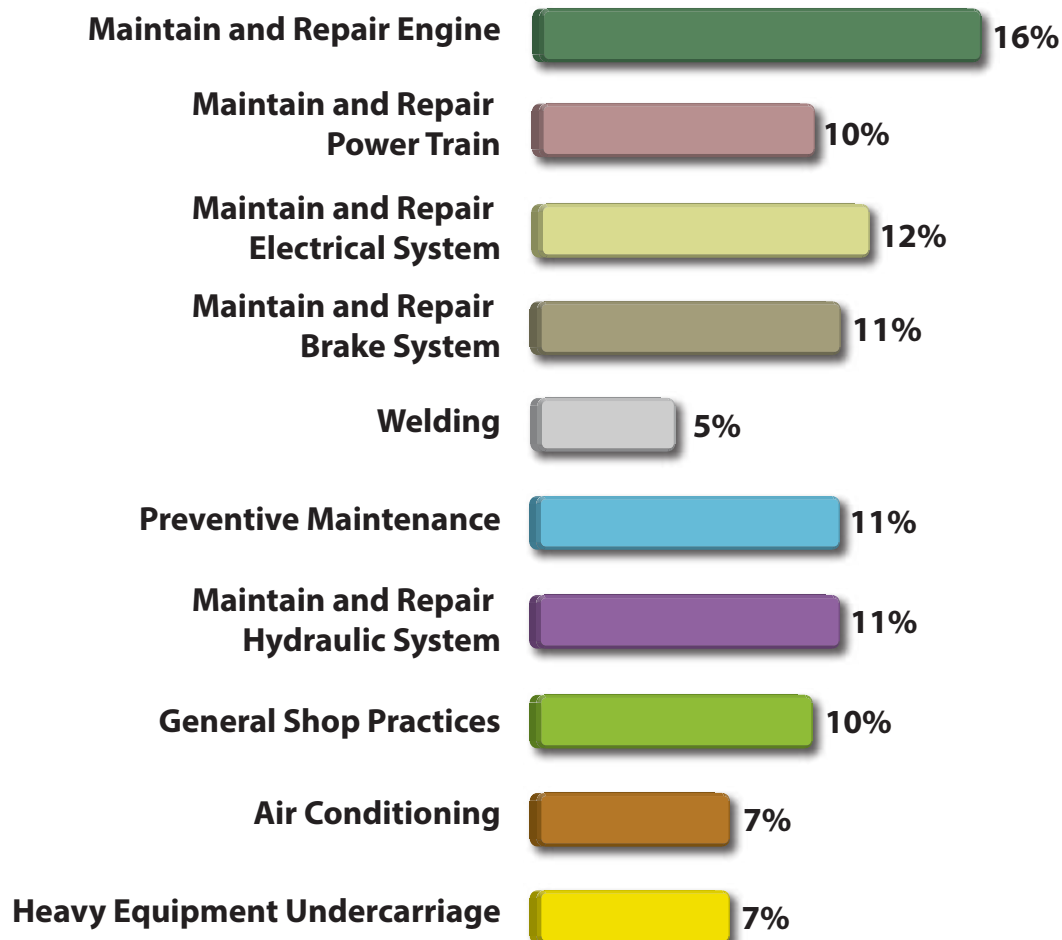

Specific Standards and Competencies Included in this Assessment

Maintain and Repair Engine

- Change oil and filters
- Maintain fuel system
- Apply knowledge of 4-stroke engines
- Maintain cooling system
- Maintain intake and exhaust systems

Maintain and Repair Power Train

- Demonstrate knowledge of hydrostatic power train
- Service and repair final drives
- Service power shift transmissions
- Service and inspect drive lines
- Service and maintain mechanical transmissions

Maintain and Repair Electrical System

- Maintain/repair electronic controls
- Service and test starting system
- Service and test charging system
- Service and test battery
- Maintain basic electrical system (lighting accessories)

Maintain and Repair Brake System

- Inspect air brake systems
- Apply knowledge of wet brake systems
- Apply knowledge of hydraulic brake systems
- Identify brake components

(Continued on the following page)

Specific Standards and Competencies (continued)

Welding

- Identify various types and components of metals
- Apply knowledge of shielded metal arc welding
- Demonstrate safe use of welding and fabrication tools

Preventive Maintenance

- Inspect and maintain tire performance
- Monitor gauges and warning lights
- Inspect hydraulic system
- Adhere to maintenance schedules and manage record keeping
- Measure and maintain oil and fluid levels
- Perform oil sampling



(Continued on the following page)

Specific Standards and Competencies (continued)

Maintain and Repair Hydraulic System

- Identify basic hydraulic system components
- Describe operation of various hydraulic pumps
- Service and troubleshoot hydraulic system, valves, and pressure controls
- Apply knowledge of hydraulic schematic symbols
- Apply knowledge of hydraulic circuits
- Service and rebuild hydraulic cylinders

General Shop Practices

- Identify personal protective equipment (PPEs)
- Select proper fasteners
- Select and use sealants properly
- Perform drilling and tapping operations
- Describe proper use of hand tools
- Demonstrate safe use of jacks and lifting equipment



(Continued on the following page)

Specific Standards and Competencies (continued)

Air Conditioning

- Identify air conditioning components
- Maintain air conditioning system
- Recover and recharge air conditioning systems
- Troubleshoot air conditioning malfunctions

Heavy Equipment Undercarriage

- Inspect undercarriage and components
- Demonstrate appropriate use of ground engaging equipment
- Perform track tension adjustments
- Demonstrate appropriate blocking/cribbing techniques

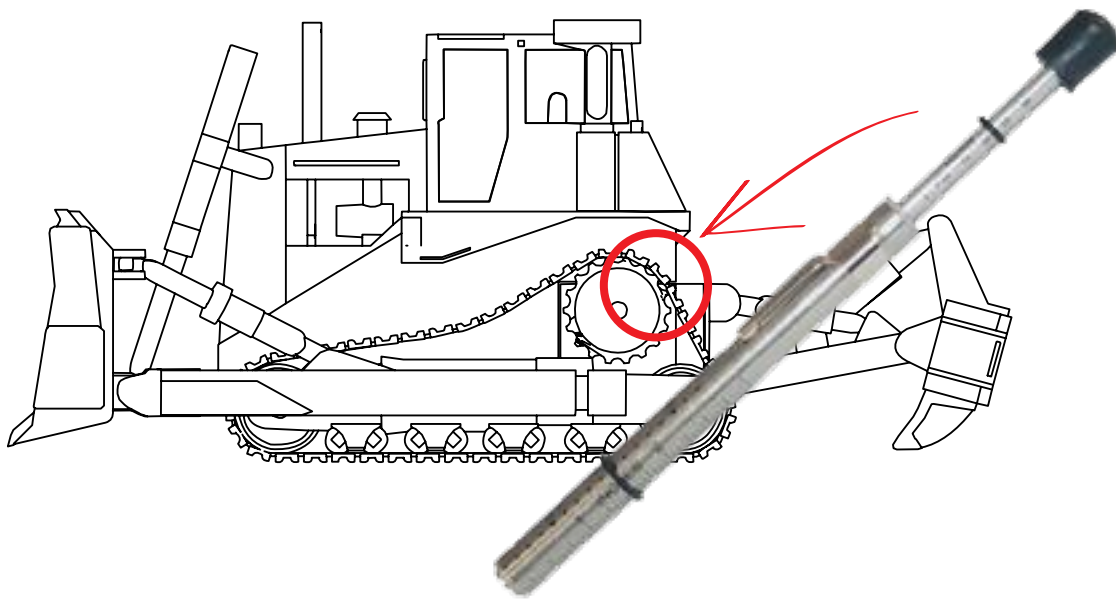

Sample Questions

Insufficient valve clearance can cause

- A. coolant leakage
- B. a burnt valve
- C. worn valve guides
- D. oil leakage

Spur gears have teeth that are

- A. curved
- B. straight
- C. herringboned
- D. beveled

The electrolyte in a battery is a solution of water and

- A. sulfuric acid
- B. baking soda
- C. viscous oil
- D. hydrogen sulfide

One sign of a defective hydraulic brake system is

- A. low gas mileage
- B. uneven tire wear
- C. non-operational stoplights
- D. low brake fluid level

The resistance of a liquid to flow is

- A. viscosity
- B. velocity
- C. reciprocity
- D. density

(Continued on the following page)

Sample Questions (continued)

The lip on a wheel seal must face toward the

- A. air
- B. vehicle
- C. fluid
- D. brakes

When conducting a starter current-draw test, the maximum time an engine should be cranked is

- A. 5 seconds
- B. 30 seconds
- C. 60 seconds
- D. 90 seconds

When checking air-pressure drop, the technician should check with

- A. the spring brake applied and the foot brake released
- B. a maximum of 45 pounds
- C. the spring brake released and the foot brake applied
- D. the supply tank drained

The weld between two metal joints on the same plane is called a _____ weld.

- A. pass
- B. butt
- C. bevel
- D. tack

A hydrostatic circuit is considered to be a/an _____ system.

- A. open center
- B. closed center
- C. closed loop
- D. centrifugal flow

Performance Assessment

NOCTI performance assessments allow individuals to demonstrate their acquired skills by completing actual jobs using the tools, materials, machines, and equipment related to the technical area.

Administration Time: 2 hours and 25 minutes

Number of Jobs: 7

Areas Covered:

10% Test Cooling System

Participants will test cap pressure, record pressure loss, and test for and record leaks in system.

19% Electrical Testing

Participants will perform a battery discharge test, starter draw test, and alternator maximum output test.

12% Adjust Valve Clearance

Participants will record specifications, position the engine for valve adjustment, and record initial and final measurements for valve clearance.

14% Set Carrier Bearing Ring and Pinion Backlash

Participants will set carrier ring and pinion backlash, and measure and record backlash.

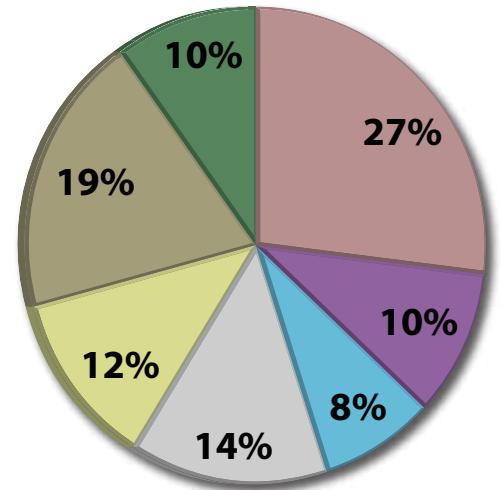

(Continued on the following page)

Areas Covered (continued)

8% Identify Brake Components

Participants will identify brake components.

10% Measure and Adjust Track

Participants will perform a lock-out tag-out procedure, record specifications, record track measurement, circle correction action needed, adjust track and record measurement, and remove lock-out tag-out.

27% Cut and Weld Steel

Participants will set up oxyacetylene cutting, set up the welder, accurately weld and cut, achieve good penetration, give the weld a smooth appearance, and have quality cut edges.

Sample Job

Cut and Weld Steel

Maximum Time: 20 minutes

Participant Activity: The participant will use the proper tools and equipment to cut steel using the pattern provided. Attach the cut piece as shown in the drawing provided using a butt weld.

