

Industrial Electronics

General Assessment Information

Blueprint Contents

General Assessment Information	Sample Written Items
Written Assessment Information	Performance Assessment Information
Specific Competencies Covered in the Test	Sample Performance Job

Test Type: The Industrial Electronics industry-based credential is included in NOCTI's Job Ready assessment battery. Job Ready assessments measure technical skills at the occupational level and include items which gauge factual and theoretical knowledge. Job Ready assessments typically offer both a written and performance component and can be used at the secondary and post-secondary levels. Job Ready assessments can be delivered in an online or paper/pencil format.

Revision Team: The assessment content is based on input from secondary, post-secondary, and business/industry representatives from the states of Connecticut, Kentucky, Michigan, North Carolina, Pennsylvania, and Tennessee.



47.0105- Industry Electronics
Technology/Technicians



Career Cluster 15-
Science, Technology, Engineering,
and Mathematics



49-2094.00- Electrical
and Electronic Repairers



The Association for Career and Technical Education (ACTE), the leading professional organization for career and technical educators, commends all students who participate in career and technical education programs and choose to validate their educational attainment through rigorous technical assessments. In taking this assessment you demonstrate to your school, your parents and guardians, your future employers and yourself that you understand the concepts and knowledge needed to succeed in the workplace. Good Luck!

(Continued on the following page)

General Assessment Information (continued)



Electronics Technicians Association® International (ETA®) represents and supports electronics professionals with over 80 industry-recognized and accredited technical certifications. An ETA certification validates the technical knowledge and hands-on skills necessary to be successful in today's electronics industry. Employers worldwide choose ETA-certified professionals because of ETA's certification programs' competency criteria and testing benchmarks that conform to the highest international electronics standards. Students passing NOCTI assessments in the area of electronics, industrial electronics and electronics technology are prime candidates to achieve success earning ETA certifications and will be qualified to enter today's workforce. www.eta-i.org



NATIONAL COLLEGE CREDIT RECOMMENDATION SERVICE
University of the State of New York - Regents Research Fund

In the lower division
baccalaureate/associate degree
category, 3 semester hours in
Industrial Electronics

Written Assessment

NOCTI written assessments consist of questions to measure an individual's factual theoretical knowledge.

Administration Time: 3 hours

Number of Questions: 197

Number of Sessions: This assessment may be administered in one, two, or three sessions.

Areas Covered

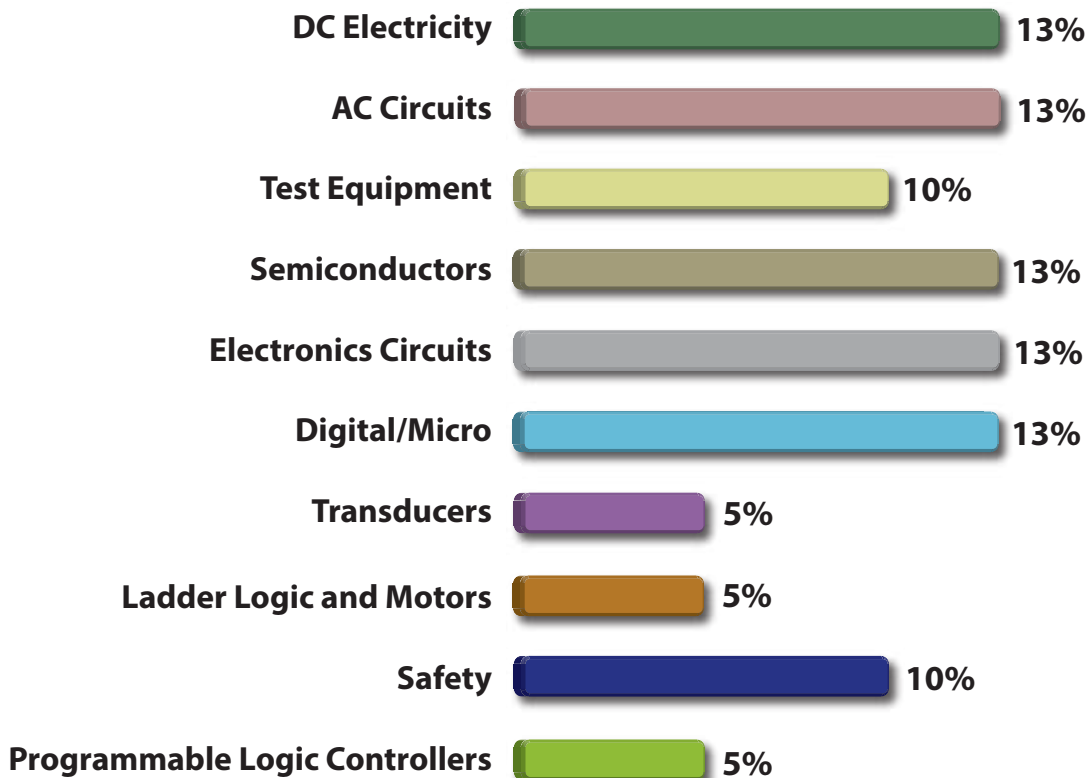

Specific Standards and Competencies Included in this Assessment

DC Electricity

Demonstrate the ability to identify and use the principles of the following:

- Ohm's Law
- Kirchhoff's Law
- Watt's Law
- Series, parallel, series-parallel
- Capacitance
- Inductance
- Voltage cells
- Schematic symbols
- Time constants

AC Circuits

Demonstrate the ability to identify and use the principles of the following:

- Transformer action
- Resonance
- Voltage conversion (RMS, peak, etc.)
- Waveform analysis
- Degrees of displacement
- Reactance
- Impedance
- Filters
- Power factor
- Time/frequency

Fundamentals (covered in the performance test)

Demonstrate the ability to identify and use the principles of the following:

- Component identification
- Circuit characteristics
- Wiring specifications
- Circuit protection

(Continued on the following page)

Specific Standards and Competencies (continued)

Test Equipment

Demonstrate the ability to identify and use the principles of the following:

- Meter fundamentals
- Oscilloscope operation
- Digital meters
- Milliohm meter
- Transfer curve tracer
- IC analyzer
- Logic probe/pulser probe

Semiconductors

Demonstrate the ability to identify the use of the principles of the following:

- Diode fundamentals (bipolar-zener applications)
- Transistor fundamentals
- Field effect transistor (FET) fundamentals

Electronic Circuits

Demonstrate the ability to identify and use the principles of the following:

- Transistor amplifier fundamentals
- Operational amplifier fundamentals
- Differentiator/integrator op-amps circuits
- Voltage regulators
- 555 Timers
- Power supplies
- Oscillators
- Phase-lock loop circuits

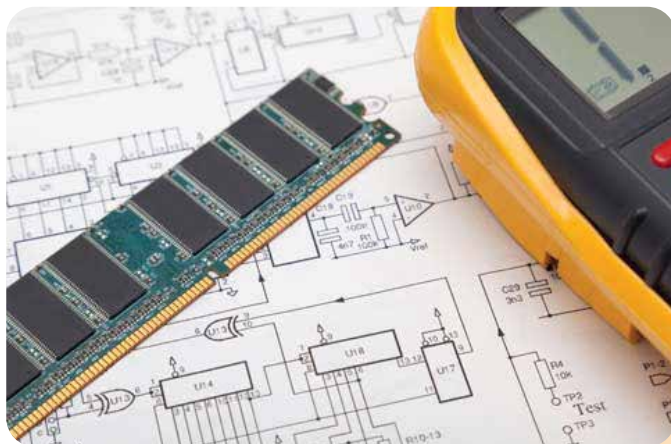

(Continued on the following page)

Specific Standards and Competencies (continued)

Digital/Micro

Demonstrate the ability to identify and use the principles of the following:

- Basic gates
- Boolean expression
- Gate circuits
- Logic specifications
- Circuit identification
- Counter circuits
- Microprocessor fundamentals
- Latches/flip-flops
- Binary numbering systems
- Discrete gates
- D/A, A/D
- Multiplexers/demultiplexers

Transducers

Demonstrate the ability to identify and use the principles of the following:

- Thermistors
- Resistive temperature detectors (RTDs)
- Optical devices
- Thermocouples
- Proximity and resistive devices

(Continued on the following page)

Specific Standards and Competencies (continued)

Ladder Logic and Motors

Demonstrate the ability to identify and use the principles of the following:

- DC motors
- Synchro-systems
- AC induction motors
- Horsepower ratings
- Three-phase power
- Motor starter circuits
- Ladder diagrams
- JIC symbols

Safety

Demonstrate the ability to use principles of safety for the following:

- Personal/shop/equipment

Programmable Logic Controllers

Demonstrate the ability to identify and use the principles of the following:

- PLC programming (ladder logic)
- PLC input/output capabilities
- PLC field wiring
- PLC trouble shooting

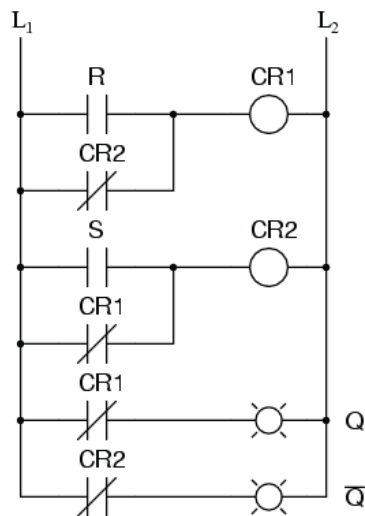

Sample Questions

A positive ion is produced when an atom

- A. loses an electron
- B. loses a proton
- C. gains an electron
- D. gains a proton

If a transformer with a 1:5 ratio is rated at 500 volt-amperes and has an input voltage of 100 volts, what would be the output current assuming 100 percent efficiency?

- A. 1.0 amp
- B. 2.5 amps
- C. 5 amps
- D. 25 amps

To remove a DC offset from the output of a frequency generator connected to a test circuit, the technician must

- A. change the DC bias on the test circuit
- B. place a capacitor in series with the output of the generator and the test circuit
- C. change the scope probe setting to times 10
- D. set the scope to measure AC

The junction field effect transistor (JFET) operates in the _____ mode.

- A. depletion
- B. enhancement
- C. depletion or enhancement
- D. depletion and enhancement

A 4-input NOR gate has how many possible input conditions?

- A. 2
- B. 4
- C. 8
- D. 16

(Continued on the following page)

Sample Questions (continued)

Two 40-microfarad capacitors rated at 150 volts each, connected in series, would have a combined rating of

- A. 20 microfarads at 150 volts
- B. 20 microfarads at 300 volts
- C. 80 microfarads at 300 volts
- D. 80 microfarads at 150 volts

Inductance is the electrical property that

- A. opposes DC more than AC
- B. converts electricity into heat
- C. opposes changes in current
- D. opposes changes in voltage

The DIAC is also known as a

- A. unilateral switch
- B. bilateral switch
- C. Zener diode
- D. blocking oscillator

An SCR is basically a

- A. silicon transistor with a base, emitter, and collector
- B. PNP device with four leads attached to the four layers
- C. PNP device with a gate, cathode, and anode leads
- D. three layer device with a gate, base, and anode

A transducer is a device that

- A. conveys a process variable from one point to another
- B. transmits a signal from a sensing element to an instrument
- C. converts low mechanical power to a higher level of power
- D. converts one form of energy into another

Performance Assessment

NOCTI performance assessments allow individuals to demonstrate their acquired skills by completing actual jobs using the tools, materials, machines, and equipment related to the technical area.

Administration Time: 3 hours

Number of Jobs: 7

Areas Covered:

15% Semiconductor Testing

Participants will correctly utilize testing equipment, identify and evaluate components, identify diode, lead configuration, and whether they are defective or good, and identify transistor, lead configuration, and whether they are defective or good.

24% Solder/Desolder Components

Participants will utilize safety glasses, and tools and equipment, to solder and desolder transistor and IC chip so that components remain intact, with no damage to board or foil and correct appearance. Participants will then solder and desolder the lug connection.

16% Meter Usage

Participants will use a multimeter to measure voltage, resistance, and current.

13% Circuit Construction

Participants will properly use schematic, assemble circuit, and use proper safety procedures.

13% Oscilloscope Usage

Participants will properly use an oscilloscope and schematic to measure time and voltage.

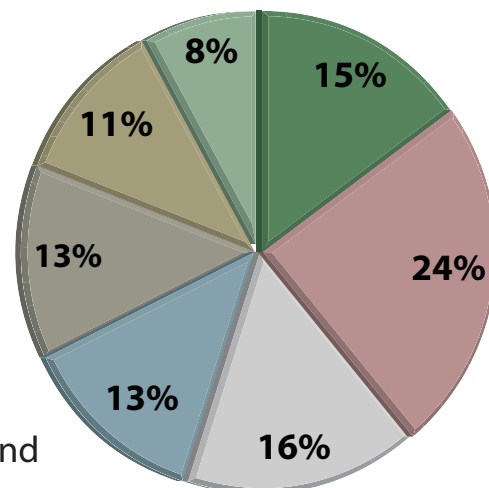

(Continued on the following page)

Areas Covered (continued)

11% Troubleshooting

Participants will properly utilize equipment, follow a logical approach of troubleshooting, select proper replacement part and demonstrate proper safety procedures.

8% Gate Substitution

Participants will utilize the logic diagram to draw the circuit equivalent and wire the circuit correctly.

Sample Job

Test Equipment

Maximum Time: 25 minutes

Participant Activity: The participant will measure the voltage drop, the current and the resistance for each resistor. Then the total voltage, current and resistance will be measured for the entire circuit.

